

Lab Project 1: Power Flow Study

Anupam Gopal and Dagmar Niebur
Electrical and Computer Engineering Dept.
Drexel University

Problem Description:

The following case study was proposed and published as part of design problem 4.1, 5.1 and 10.1 in A. R. Bergen and V. J. Vittal *Power Systems Analysis*, Prentice Hall, 2000.

This power flow study will be conducted on the test system presented below using two different simulation software packages, PowerWorld Simulator Version 8.0 and Mathpower. We will use the version of PowerWorld published in J. D. Glover and M. S. Sarma, *Power Systems Analysis and Design*, 3rd, Brooks/Cole, Pacific Grove, CA 2001. This textbook is used for the junior class ECE P 354 on Energy Management Systems.

MATPOWER is a public domain Matlab based software which can be downloaded from www.pserc.cornell.edu/matpower/ or <http://blackbird.pserc.cornell.edu/matpower/2.0/download.html>.

System Specification:

The base system introduced consists of an existing transmission system that contains 161 kV and 69 kV transmission lines which run through both urban and rural service territory. The existing load at the various buses in the system is specified. The parameters of the existing transmission lines in the system are also provided. The load centers and the power sources of the Eagle Power System are shown in Fig.1.1. The figure is scaled based on the distances given in Table 1.1. Note the urban area of the system. Table 1.1 specifies the transmission line and transformer data. Table 1.2 provides the load data.

System Bus Names and Loads:

Buses 1-3 are power sources at 161 kV

Buses 4-8 are urban load buses

Buses 9-15 are rural load buses

Buses with loads under 30MVA should be served at 69 kV and buses with loads over 50 MVA should be served at 161 kv. Other buses can be served at either voltage,

A base case system is provided. The details of the base case system are as follows:

There are 69kV-161kV 60MVA transformers at the Siskin and Crow buses. Each of the buses is split into two parts. At Siskin, the high voltage side is labeled bus 9, while the low voltage side is labeled bus 17. At Crow, the high voltage side is labeled bus 15, while the low voltage side is labeled bus 16.

A. Generation:

1. Make OWL (bus 1) the swing bus.
2. For the generation at SWIFT (bus 2) and at PARROT (bus 3), set the reactive power limits $Q_{\min} = -100.0$ MVar, and $Q_{\max} = 250.0$ MVar for both generators. Set both active power limits $P_{\max} = 430$ MW.
3. For the generation at SWIFT (bus 2) and at PARROT (bus 3), set both active generation as $P_{\text{gen}} = 190$ MW. Since the voltage magnitudes is usually highest at generators and since 1.04 is at the upper limit of acceptable voltage magnitudes, schedule the voltage magnitudes on the three generators at or near 1.04 p.u.

B. Lines

Take the short-line model, i.e. ignore the shunt capacitances given implicitly through the BMVA parameters. The maximum current carrying capacity (or *ampacity*) of the conductors are:

- Partidge: 475A
- Hawk 659A
- Dove 726A
- Drake 907A
- Cardinal 996A

C. Transformer

For the transformers we have $X_T=0.08$ pu at 60 MVA Base. Assume a limit of 20MVA.

D. Areas:

Assign urban buses to a different area than rural buses. Use area interchange data for each area (this is needed if your power flow program provides this option), including the maximum and minimum acceptable voltages.

E. Title:

For each power flow case you run, title lines should be used to describe the case.

F. Data Checking:

Since data *must* be in the correct columns in data input to the MATPOWER power flow program, spend time checking the computer output. Also check to see that all lines are connected to the correct buses. Send the Matpower case to the TA for verification.

G. Power Flow Control Parameters:

Choose MATPOWER's default values, i.e. an accuracy of 10^{-8} and a maximum number of iterations of 10. (Control parameters are specified in MATPOWER's file mption.m.)

Base case 1: System with base loads and fixed tap transformers

Examine the power flow output and verify the following for the base case design:

1. *Satisfactory system operation:* All voltages should be in the range from 0.96 to 1.04 p.u., with no overloaded lines or transformers.
2. *Loads:* From the power flow summary report, determine the total load in the system, the losses, and the total generation. What is the generation at the slack bus?
3. *Transformers:* The transformer tap should be fixed at 1.00 per unit (Tap 1 is 69 kV and Tap 2 is 161 kV) in the power flow for Case 1 (not a regulating transformer).

Base case 2: System with base loads and regulating transformers

Regulating Transformers: Set each transformer to regulate the voltage on the 69-kV bus. Select a scheduled voltage and include it in the bus data. Specify a tap range of (0.9 to 1.1 per unit) 62.1 kV to 75.9 kV

Power Flow Report

The report should be typed. Use of a word processor would be helpful since portions of the report will need to be updated in other phases of the design project.

This report should include the following:

1. Title page and table of contents.
2. A one-line diagram of the system showing the bus, line, transformer, and load connections.
3. The power flow showing the voltages and the loadings.
4. The powerflow of each of the two cases showing voltages and the loadings. Include a table with the power flow output.
5. Number and title all figures and tables.
6. What is the total power (P) loss in the system as a percentage of the total load for each case? Compare the MVA in the loads, the MVA used in the lines and the transformers, the MVA from line charging, and the MVA from the generators for each case.

Starters Guide:**A. In order to successfully run power world in the lab please follow the following steps in sequential order:**

1. Login to the system as student.
2. Open the power world simulator- "Glover and Sarma" version by going to start menu >programs>power world>power world simulator for Glover and sarma.
3. In order to start working on an existing case or start a new case follow the directions in the "PW100 USER GUIDE. PDF" on web ct.
4. To save the work that you have done so far, select **File > Save Case** from the main menu, or click on the *Save Case* button. Before the case is saved, Simulator validates the case to make sure that it does not contain any errors. Results from this validation are displayed in the Message Log display, usually shown in the lower right-hand corner of the display. Enter the filename and select OK. By default the case is saved using the PowerWorld Binary format (*.pwb). When saving the case in the future, you will not have to reenter its name. Simulator also asks you to supply a name for saving the oneline diagram we have been drawing. The oneline diagram files have a default extension of *.pwd, which identifies them as PowerWorld Display files. Supply the same name as you gave to the cas e. Note that, because the case and the oneline are stored in separate files, multiple onelines can be assigned to the same case, and the same oneline can be used by many cases.

B. In order to successfully run mat power in the lab please follow the following steps in sequential order:

1. Login to the system as student.
2. Open matlab.
3. Change the current directory location to "D:\Matpower-3".
4. The list of files in the folder Matpower-3 appears on the left side of the screen in the "Current Directory" window.
5. Open one of the existing cases (M- file) by double clicking on it.
6. After making necessary modifications to the file run it in matlab by typing the command "runpf('caseXX').
7. Result of the power flow is displayed in the command window.

Remarks:

- Please turn in the mat lab data file before running the power flow on it. This would help in validating the data and making corrections if any.
- Please run the Matpower simulation before running the Power world simulation as it would help in debugging the data in case if the solution doesn't converge.

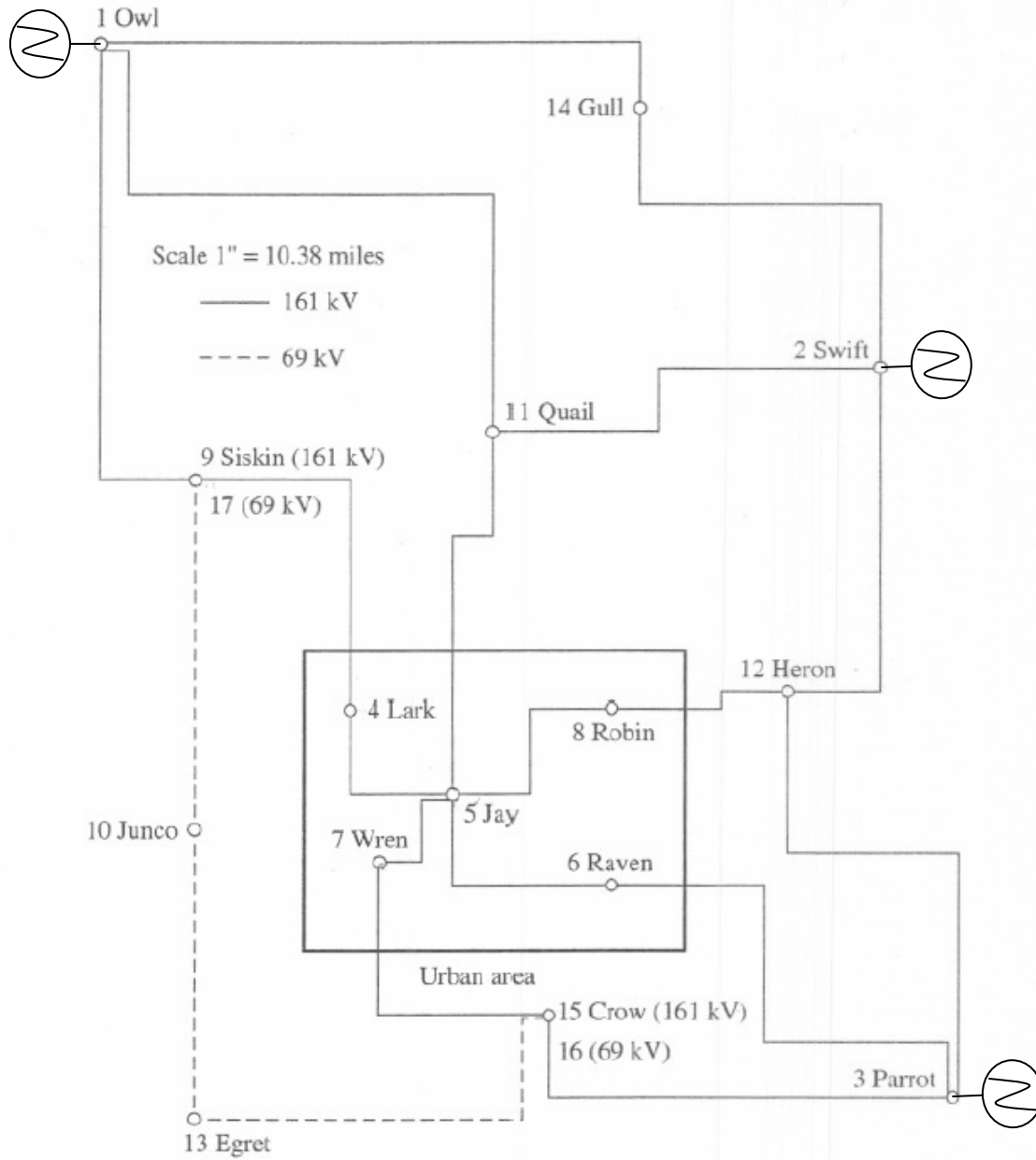

Eagle Power System Transmission Map
Figure:1.1 Eagle Power System Transmission Map

Table 1.1 Transmission Line Parameters

Bus#	Bus#	Bus Name	Bus Name	Miles	Conductor	R- Ω	X- Ω	BMVA ¹
1	9	Owl 161	Siskin 161	24.0	Drake	3.085	17.47	3.629
1	11	Owl 161	Quail 161	36.7	Drake	4.718	26.70	5.550
1	14	Owl 161	Gull 161	28.2	Drake	3.629	20.53	4.264
2	11	Swift 161	Quail 161	21.5	Drake	2.774	15.66	3.251
2	12	Swift 161	Heron 161	20.3	Drake	2.618	14.78	3.070
2	14	Swift 161	Gull 161	24.0	Drake	3.085	17.47	3.629
3	6	Parrot 161	Raven 161	27.6	Drake	3.551	20.09	4.174
3	12	Parrot 161	Heron 161	27.6	Drake	3.551	20.09	4.174
3	15	Parrot 161	Crow 161	23.6	Drake	3.033	17.16	3.569
4	5	Lark 161	Jay 161	8.4	Dove	1.529	6.30	1.232
4	9	Lark 161	Siskin 161	18.8	Drake	2.411	13.69	2.843
5	6	Jay 161	Raven 161	10.8	Dove	1.970	8.09	1.584
5	7	Jay 161	Wren 161	6.0	Dove	1.089	4.48	.880
5	8	Jay 161	Robin 161	10.9	Dove	1.996	8.17	1.599
7	15	Wren 161	Crow 161	14.6	Drake	1.866	10.63	2.208
8	12	Robin 161	Heron 161	9.8	Drake	1.270	7.13	1.482
5	11	Jay 161	Quail 161	19.5	Drake	2.514	14.18	2.949
10	13	Junco 69	Egret 69	14.3	Hawk	3.033	10.15	.408
10	17	Junco 69	Siskin 69	16.2	Hawk	3.433	11.49	.462
13	16	Egret 69	Crow 69	21.9	Hawk	4.642	15.54	.624

¹The BMVA is the volt-amperes reactive generated by the total susceptance corresponding to the line charging of the transmission line at the rated voltage.

Table 1.2 Existing Loads at Various Busses

Bus #	Bus Name	Load-MW	Load-MVAr
1	Owl		
2	Swift		
3	Parrot		
4	Lark	60	10
5	Jay	100	30
6	Raven	80	15
7	Wren	90	20
8	Robin	40	5
9	Siskin	10	5
10	Junco	15	10
11	Quail	75	15
12	Heron	40	15
13	Egret	30	10
14	Gull	35	10
15	Crow	10	0
		<u>585</u>	<u>145</u>

