

# Hardware Design and Layout of a *Reconfigurable Power Distribution Automation and Control Laboratory (RDAC)*

Karen Miu, Chika Nwankpa, Xiaoguang Yang and Anthony Madonna

Department of Electrical and Computer Engineering  
Drexel University  
Philadelphia, Pennsylvania

**Abstract:** This paper will present the hardware design and detailed physical layout of a scaled power distribution system laboratory under construction at Drexel University. Engineers with formal knowledge about power distribution systems are needed to design, upgrade and operate large-scale distribution power systems and their automation and control techniques. In response, at Drexel, we are developing a power distribution systems curriculum centered around a reconfigurable *distribution automation and control laboratory*, RDAC. This paper focuses on the physical layout and presentation of large-scale distribution power systems.

## I. INTRODUCTION

A renewed focus on maintaining and improving reliability and power quality has highlighted the need for increased monitoring and control of power distribution systems both in the utility and within industrial plants and buildings. Brought on by utility restructuring efforts and the continued thrust towards deployment and use of automated devices, industries, such as power distribution companies, automotive companies, architectural engineering firms, ship builders, pharmaceuticals, etc., are increasingly concerned with their energy systems and hire engineers for the planning and operation of lower power, lower voltage (<115kV) distribution systems.

As such, the topic of power distribution systems has been addressed at several universities in terms of classes and software laboratories, with a smaller number of universities addressing hardware laboratories. Some existing laboratories are now discussed. Software laboratories explicitly for distribution system planning can be found in [1]. At the University of Florida, a hardware laboratory was established for power quality and energy studies [2]. In Taiwan, a distribution automation laboratory was created for wider types of studies [3]. More recently, at Milwaukee School of Engineering, [4] documents the development of a building electrical power systems design specialty where a link between architectural engineering and industrial plant management is created with power distribution system studies.

At Drexel, an interconnected power system laboratory (IPSL), focusing on generation and transmission studies, has been incorporated into the existing ECE curriculum [5][6] and disseminated and reproduced at the University of Hong Kong. IPSL has successfully combined four existing generation and transmission system laboratories into an interconnected three-bus power system with real-time data acquisition. It is envisioned that the power distribution system focus of RDAC will complement the generation and transmission oriented laboratories already

available. RDAC will provide students with hands-on learning experiences in the analysis, operation and planning of electric power distribution systems.

A comprehensive curriculum is targeted to expose all electrical and computer engineering students to power distribution systems through RDAC laboratory modules and to provide more formal education to upper-level electrical engineering students through full courses and laboratories. RDAC is designed to be reconfigurable both in its physical construction and electrically, through computer and manually controlled devices. With embedded network switches allowing for reconfiguration of electrical connections, RDAC can address second-year level material such the differences between parallel and series connections of impedances and other basic circuit theory concepts in the context of power distribution networks. At a more advanced level, the flexibility of the distribution network will allow students to perform experiments in three-phase power flow analysis, network reconfiguration of load balancing, service restoration after faults and capacitor placement for voltage regulations. At a senior design/capstone and graduate level, students may design and test their own control schemes and measure the effects different distribution automation and control schemes have on the system.

RDAC consists of four modular stations that can combine for a total of 36 buses, 16 lines, 16 normally closed switches and a number of possible load connections. A supervisory control and data acquisition (SCADA) system has also been designed with facilities such as signal conditioning hardware, data acquisition equipment, and remote terminal units (RTUs). The SCADA system will allow students to view network voltages, currents, and power flow in a user friendly and realistic manner. Procedures and results of detailed hardware equipment tests performed on components listed and depicted in this paper were presented in [7]. In this paper, special attention to the layouts of the hardware components and the entire laboratory has been made to facilitate the presentation of large numbers of interconnected components. In addition, the modular construction and the physical layout are designed to accommodate several groups of students and several interchangeable experiments

This paper presents the electrical and physical layout of a three-phase, 36 bus, reconfigurable, power distribution system. The distribution system will be typically operated in an electrically radial manner with 4 identical student laboratory stations focusing on 8 buses each. Within each laboratory station four main parts exist: (i) the power station, (ii) the distribution feeder box, (iii) the transfer station and (iv) a PC for data acquisition and computer control. The paper progresses by introducing the entire power distribution laboratory layout and then focuses on individual stations used to supply power, deliver power and transfer power.

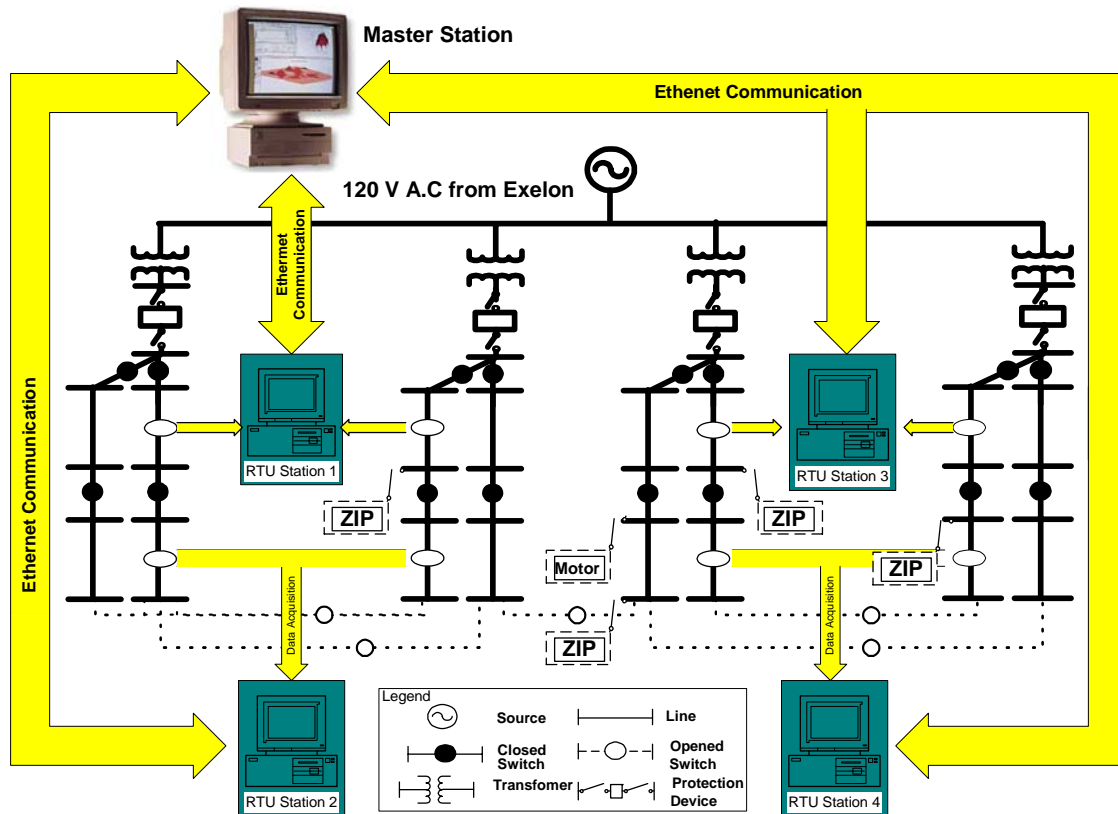

Figure 1. One-line diagram of the 7 kW three-phase RDAC laboratory in a typical setup

## II. LABORATORY OVERVIEW AND LAYOUT

A general laboratory electrical configuration and physical layout are now discussed. The electric infrastructure of RDAC will be multi-phased and normally operated in a radial manner. It can be reconfigured conveniently for different experiments. A one-line diagram of a general configuration of RDAC is shown in Figure 1. Please note, in this layout, four identical feeders each with one branching lateral can be identified.

The system will normally be operated at a frequency of 60Hz and a voltage level of 120V phase to neutral. However, it can also be reconfigured to operate as a DC system. RDAC consists of the following, where detailed descriptions of components can be found in [12]:

- An AC source providing power for typical loading conditions, up to 7kW with four feeders connected;
- A DC source (achieved by using an industrial three-phase rectifier)
- 4 1:1 variable three-phase auto transformers;
- 4 three-phase over-current circuit breakers with maximum current of 30A, which correspond to the protection devices in Figure 1;
- 4 feeders with one lateral on each feeder: for a total of 16 three-phase lines represented by 48 inductors each with a 20A current rating;
- 48 normally opened and 48 normally closed digital relays are used to model 16 three-phase sectionalizing switches and 16 three-phase tie switches. Each relay can be controlled individually;

- ZIP loads with various compositions, including individual constant impedance, constant current, and constant power loads. They can be connected in both balanced and/or unbalanced fashions.
- Hall-effect devices, for AC and DC measurements, at each phase of the sending and receiving end of each line.
- Signal conditioning boards and data acquisition boards for data acquisition.
- 4 remote terminal units: represented by PC's which display acquired data

Given the large number of components used to construct the distribution laboratory, a physical layout is documented in Figure 2 to facilitate educational content delivery to students. Specifically, it is possible that students and users of RDAC may be overwhelmed if the components are not arranged in an orderly fashion.

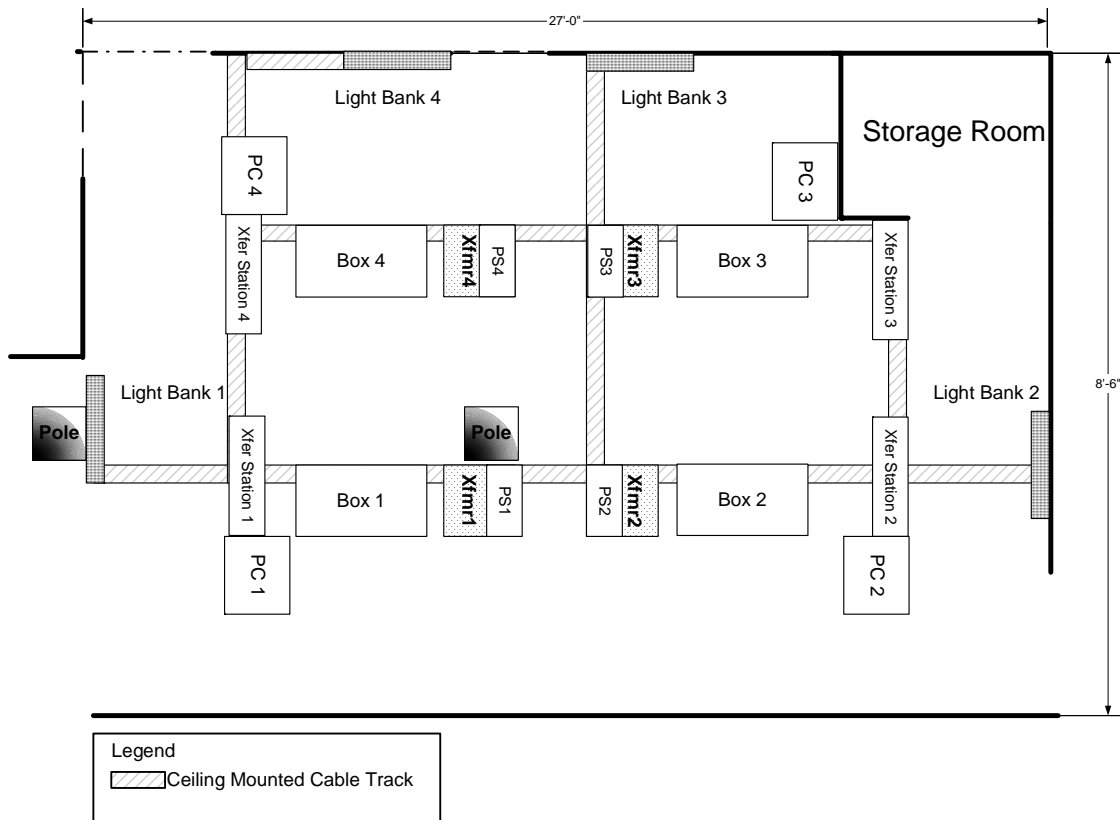

Figure 2. A Typical Physical Layout/Floorplan of RDAC within the Center for Electric Power Engineering at Drexel University

Within approximately 500 square feet of space, four identical laboratory stations have been created to emulate the distribution system from Figure 1. The typical, physical layout of the lab stations is indicated in Figure 2, where each feeder will be enclosed in a distribution feeder box (Box #), which is fed from a power station (PS#) and connections are made through transfer stations (Xfer Station #). Also, each distribution feeder box, transformer (Xfmr #) and PC are modular and mounted on carts with casters to allow for different configurations of the power network. This built-in mobility will allow flexible setups; for example, any two feeders can be connected in series to form one long feeder with two laterals. Cable tracks have been suspended from the ceiling and out of view to run wiring for permanent electrical connections.

Tie switches or normally open switches in the network can join any two buses between the feeders through a transfer panel (Transfer Station #). This transfer station also allows resistive loads, inductor carts, capacitor banks and motors connected as loads to buses along the feeder. Note, resistive loads are permanently mounted on panels (Light Bank #) and can be manually controlled as 3-phase, 2-phase and 1-phase resistive loads with carbon filament light bulbs used so students can visualize loads, load levels and low voltage phenomena when the bulbs appear dimmer.

The whole network will be monitored and controlled by a SCADA system, which consists of four personal computers (PC) as remote terminal units (RTU's) and a master station. The data acquisition system and laboratory layout will allow up to 4 groups of students to acquire data and to perform network studies. Four National Instrument's PCI-6071E data acquisition cards (DAQ) will be installed in the PCs to capture data and data can be shared through an Ethernet between the RTUs and the master station. Depending on the specific experiment, care must be taken to design the appropriate number of measurements and sampling rates required for each experiment. This remains as future work.

In summary, each lab station consists of four main parts: (i) a power station, (ii) a distribution feeder box, (iii) a transfer station and (iv) a PC for computer control and measurement display. Within each lab station and its subsequent lumped parts, a large number of individual components must be displayed and interconnected without overwhelming students and other users. As a consequence, detailed layouts for each part have been carefully designed to maximize transfer of content. Also, the same color coding scheme has been utilized throughout RDAC: red – phase A, blue – phase B, yellow – Phase C and white for neutral (shown as black in most subsequent figures.) The following sections highlight the main features for each power station, distribution feeder box and transfer station of one laboratory station.

### **III. POWER STATION LAYOUT**

The source of the laboratory starts at the power stations. Each power station is fed by the same source, either AC or DC; however, 4 individual power stations are used, one for each lab station. The power station panel layout is shown in Figure 3. This panel allows for the connection between electrical elements either (i) a three-phase 208V source tapped from the local utility, Exelon or (ii) a 120V DC source which will be implemented using a three-phase rectifier (Major Power Industrial Power Supply). Both 50A and 25A receptacles are available. In addition, for the three-phase AC supply, individual phases may be tapped or a three-phase receptacle is available so as to reduce the number of wiring connections students would be required to make when setting up experiments.

For safety purposes, individual switches are available on the front side of the panel to control source currents and on the side panel, an emergency switch to shut off power to the entire laboratory is in place. Finally, on the side panel, 120V AC supplies are available for powering computers or any individual measurement devices if necessary.

The power stations main purpose is solely to provide power to the subsequent distribution system although it may be used for other purposes such as machine laboratories and others. Within

RDAC, the distribution system itself will be fed from the power stations and in the following section, we discuss the layout of the distribution feeders.

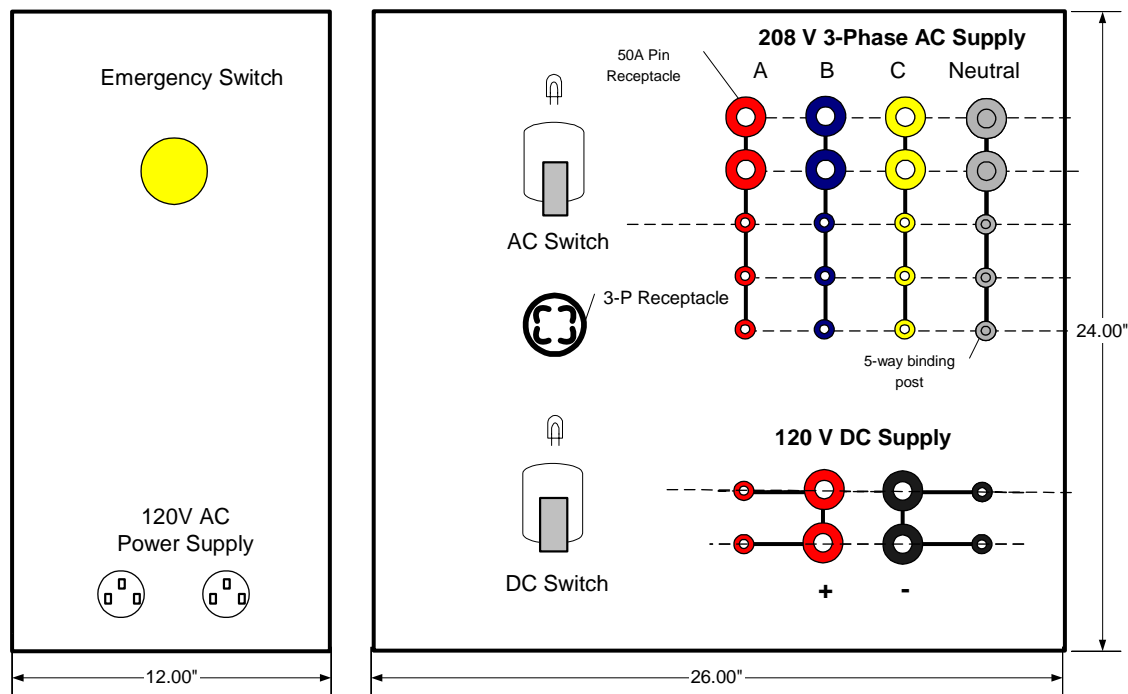

Figure 3. Power Station Layout: 3-Phase 208V AC and 120V DC Power Supplies

#### IV. DISTRIBUTION FEEDER BOX LAYOUT

The power stations will provide power to distribution feeders consisting of several distribution lines and buses where loads can be connected. Four, identical distribution feeders, each with one branching lateral, will be built within four 26"Wx44"Lx12"H boxes with Lexan tops for easy viewing. The top view of the component layout for distribution feeders and laterals is presented in Figure 4. Included within the diagram are:

- Electrical circuit elements – inductors and network switches/digital relays
- Measurement devices and a DC power source for the measurement devices
- Fuses for overcurrent protection
- Cooling fans and heat-sinks

Please note, side views of the distribution boxes, not presented within this paper, would indicate:

- Receptacles for receiving power from the power station
- Tie points to the transfer station
- Measurement receptacles to allow for connections to the signal conditioning chassis.
- Receptacles for hand held metering

We now comment on the physical layout of components within the distribution feeder box. By design, the three-phase feeder and lateral are laid out in a similar manner each within  $\frac{1}{2}$  of the box. The feeder is viewed as the circuit aligned with the fuses and the lateral is the circuit branching from the feeder and aligned with the DC power supply.

Corresponding to the laboratory layout in Figure 1 and as shown in Figure 4, each box contains 4 three-phase lines and 4 three-phase switches. Each phase of a three-phase distribution line is modeled by an 1mH inductor; and each inductor was subjected to extensive parameter tests [12]. Each phase of a switch is emulated using a normally closed digital relay and is in place to allow for experiments demonstrating network reconfiguration techniques. Again, special care has been taking in color coding the wires and receptacles used to connect each element: red – phase A, blue – phase B, yellow – Phase C and white for neutral (shown as black in the diagram.)

It remains to be seen how loads are connected to each bus along the feeders and laterals. This will be achieved through a Transfer Station and is discussed in the following section.

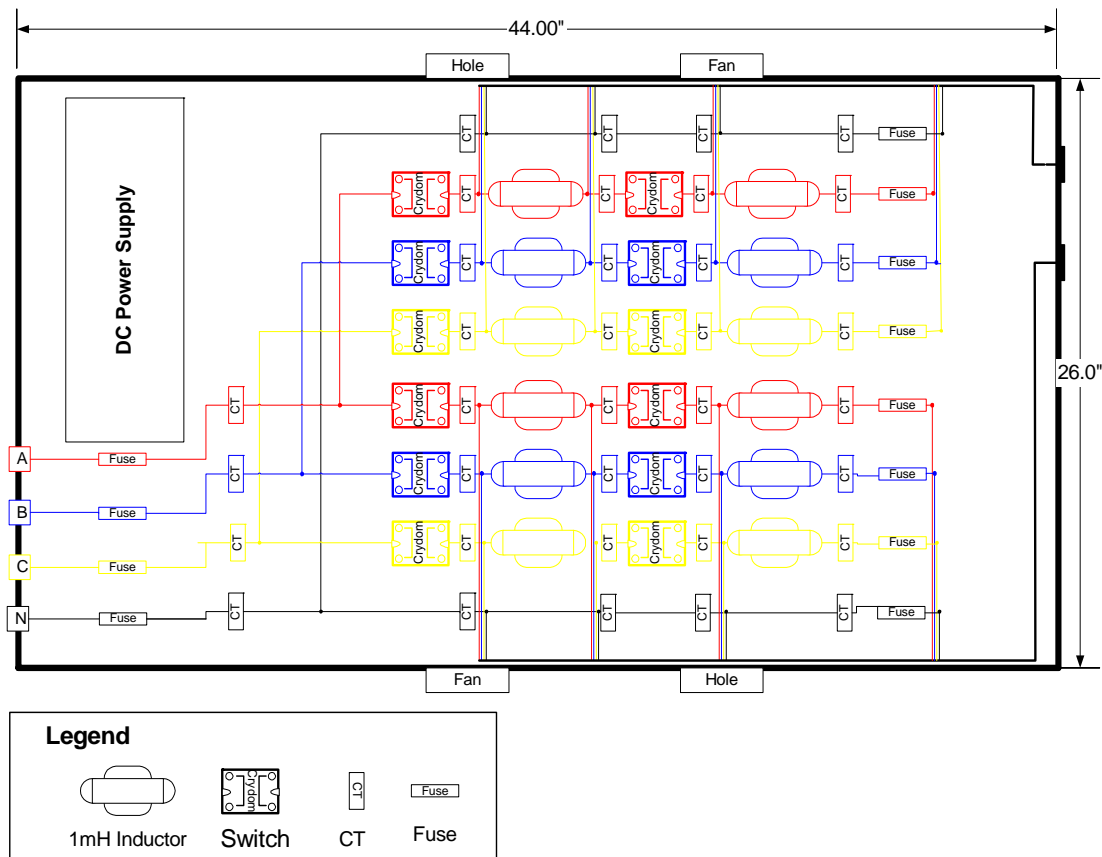

Figure 4. Distribution Feeder Box Layout: a 3-Phase Feeder with One Branching Lateral

## V. TRANSFER STATION LAYOUT

Each distribution feeder box connects to a corresponding transfer station. The layout of a transfer station can be seen in Figure 5 with the box at (40"Wx40"Lx12"D). The main purpose of the transfer station is to make electrical connections of components, such as loads and capacitors, to the buses along a feeder, denoted Feeder A (feeder) and Feeder B (lateral). Specifically, there are 4 buses along a feeder and 4 along the lateral for a total of 8 three-phase buses represented on the Transfer Station. In addition, the transfer stations allow for normally open switches or tie switches to interconnect buses which may be located on different distribution boxes; these are

connected using the “To Other Stations” receptacles. Again, the same color-coding exists on the Transfer Station and some of the other design features are as follows:

- 3-phase receptacles for easier connections and experiment setups
- single-phase receptacles to allow for single and two-phase load connections and capacitor connections
- 12 normally open digital relays used to emulate 4 three-phase tie switches
- manual or computer controlled switches for capacitors
- 6 digital relays mounted on the side panel for creating single line to ground, double line-to-ground, line-to-line faults and three-phase to ground faults.

Not shown in Figure 5 are the side and back views of the Transfer Station which include 120V AC supplies for measurement devices and RTU’s, fuses and cooling vents. Also, mounted to the bottom of each transfer station, a signal conditioning board chassis will house voltage attenuators and signal conditioning boards for the measurement system. These will connect to the distribution feeder boxes. Finally, the resistive load connections on the transfer station are hard-wired to a corresponding manual controlled load panel/light banks [12].

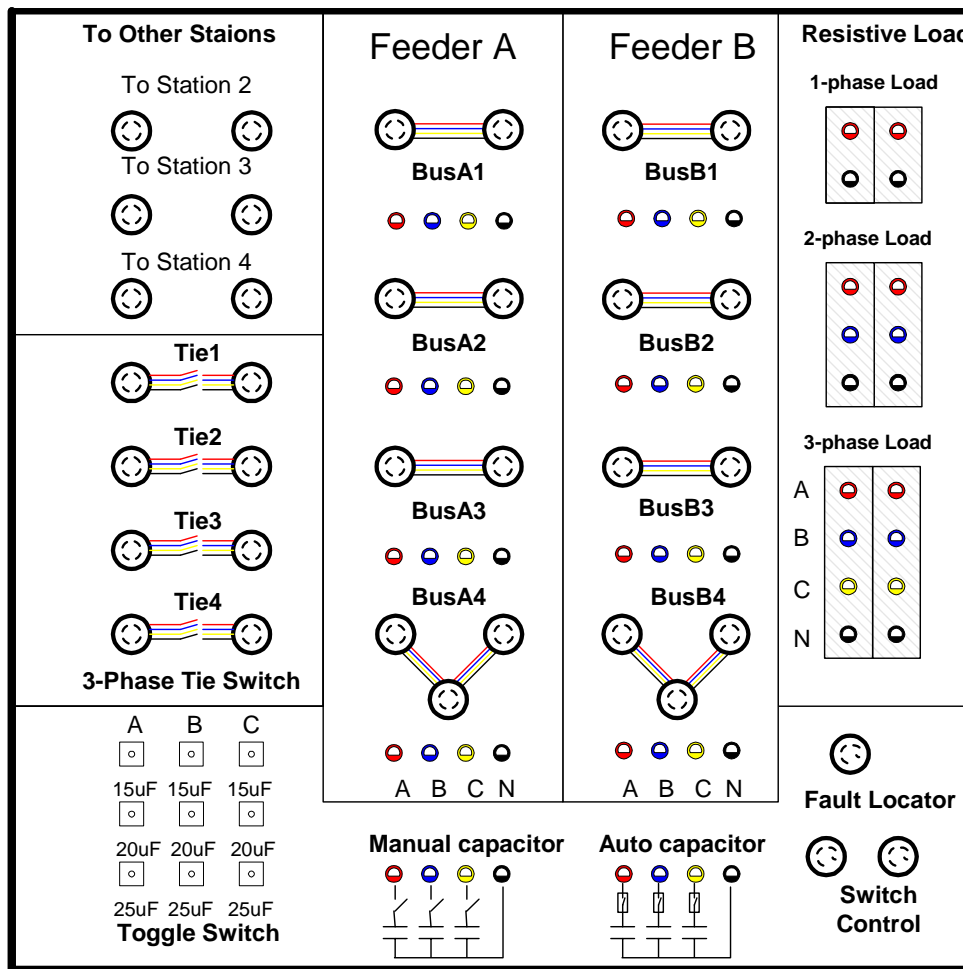

Figure 5. Transfer Station Layout: with Bus Connections, Interconnections Between Different Feeders, Multi-Phase Capacitors, Resistive Loads and Fault Creating Devices

## VI. CONCLUSIONS

This paper has documented the physical design and layout of the reconfigurable distribution automation and control laboratory (RDAC) Laboratory at Drexel University. This laboratory will be the center of a power distribution system curriculum geared towards students from the second year to the senior level and can be used in graduate level curriculum as well. The laboratory encompasses a total of 36 three-phase buses, 16 three-phase lines and 32 three-phase switches, consequently a focus on the effective delivery of technical content amongst the large-scale of the distribution system has been made. Three-phase receptacles have been employed to reduce the number of wiring connections to be made by hand and a uniform color-coding scheme for wiring and receptacles has been utilized to facilitate phase identifications. Concurrent with the laboratory construction efforts is the development of accompanying software control laboratories and RDAC is expected to be complete by summer 2002.

## VII. ACKNOWLEDGMENTS

This work was supported by NSF-DUE#9950775 and NSF-ECS#9984692.

## VIII. BIBLIOGRAPHY

- [1] A. Chandrasekaran, S. Ramkuma, "A Secondary Distribution System Design Software for Classroom Use," *IEEE Power Engineering Society 1999 Winter Meeting*, Vol. 1, 1999, pp. 243–247.
- [2] A. Domijan, E.Embriz-Santarder, "A Novel Electric Power Laboratory for Power Quality and Energy Studies: Training Aspects," *IEEE Trans. on Power Systems*, Vol. 7, No. 4, November 1992, pp. 1571-1578.
- [3] Y. Y. Hsu, N. Y. Hsiao, H. S. Jou, "A Distribution Automation Laboratory for Undergraduate and Graduate Education," *IEEE Trans. on Power Systems*, Vol. 13, No. 1, February 1998, pp. 1-7.
- [4] G. Wrate, "Development of a Building Electrical Power Systems Design Specialty", *Proceedings of the 2001 ASEE Annual Conference*, Albuquerque, NM, June 24 - 27, 2001, Session 1433.
- [5] S. P. Carullo, et al, "Interconnected Power System Laboratory: Fault Analysis Experiment," *IEEE Trans. on Power Systems*, Vol. 11, No. 4, November 1996, pp. 1913-1917.
- [6] S. P. Carullo, C. O. Nwankpa, and R. Fischl, "Instrumentation of Drexel University's Interconnected Power Systems Laboratory," *Proceeding of the 28<sup>th</sup> Annual North American Power Symposium*, Cambridge MA, October 1996, pp. 367-376.
- [7] X. G. Yang, C. Bruni, D. Cheung, Y. M. Mao, G. Sokol, K. Miu and C. Nwankpa, "Setup of RDAC – a Reconfigurable Distribution Automation and Control Laboratory," *Proceedings of the 2001 IEEE PES Summer Meeting*, Vancouver CA, July.16-21, 2001.
- [8] T. Gonen, "Electric Power Distribution System Engineering," McGraw Hill, New York NY, 1986.

## IX. BIOGRAPHIES

**KAREN MIU** received her B.S. M.S. and Ph.D. degrees in Electrical Engineering from Cornell University, Ithaca, New York. She is currently an Assistant Professor in the Electrical and Computer Engineering Department, Drexel University, Philadelphia, PA. She was awarded an NSF Career Award in 2000 and the ONR Young Investigator Award in 2001. Her research and teaching interests include power distribution system analysis and control.

**CHIKA O. NWANKPA** (S'88-M'90) received the Magistr Diploma in Electric Power Systems from Leningrad Polytechnical Institute, Leningrad, U.S.S.R., and the Ph.D. degree from the Electrical and Computer Engineering Department, Illinois Institute of Technology, Chicago, in 1986 and 1990, respectively. He is currently an Associate Professor in the Electrical and Computer Engineering Department, Drexel University, Philadelphia, PA.

**XIAO GUANG YANG** received his B.S. and M.S. from XJTU, P.R. China, in 1994, and 1997, and his second M.S. degree from NTU, Singapore, in 1999. He is currently pursuing a Ph.D. in the Electrical and Computer Engineering Department, Drexel University, Philadelphia, PA.

**ANTHONY MADONNA** is currently a sophomore in the Electrical and Computer Engineering Department at Drexel University and is working as an undergraduate research assistant for the Center for Electric Power Engineering at Drexel.